

# ASSEMBLY INSTRUCTIONS GT 150 CONNECTION SYSTEM

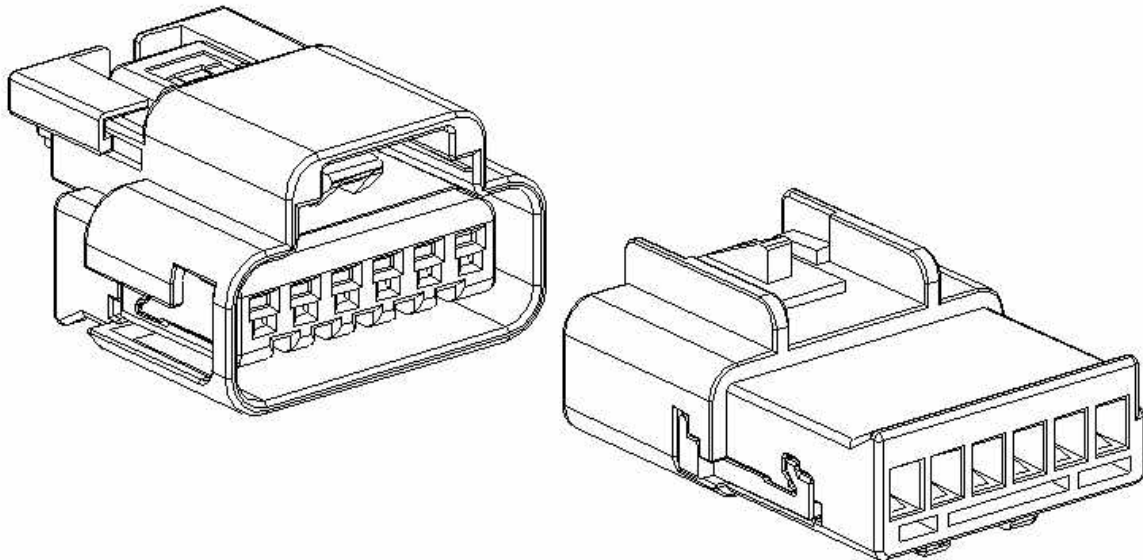

**REPRESENTATIVE WITH ANY QUESTIONS OR COMMENTS CONCERNING THESE ASSEMBLY INSTRUCTIONS. COMPONENT P/N'S AND REPAIR TOOL P/N'S ARE AVAILABLE FROM YOUR DELPHI SALES ENGINEER.**

### ASSEMBLY INSTRUCTIONS FEMALE GT 150 CONNECTOR ASSEMBLY

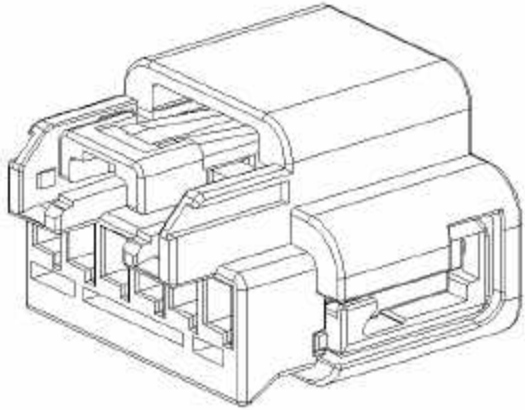

CONNECTOR ASSEMBLY

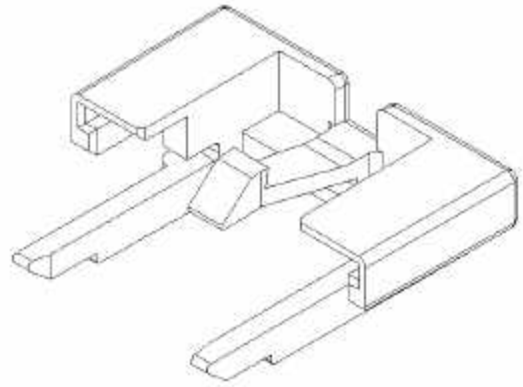

CPA

## **ASSEMBLY INSTRUCTIONS FEMALE GT 150 CONNECTOR ASSEMBLY**

**STEP 1:** PLUG LEADS TO CONNECTOR ASSEMBLY PER PRINT.

**STEP 2:** AFTER ALL LEADS ARE BUILT, SEAT SIDE LOCK COVER (SLC). APPLY PRESSURE WITH FINGERS UNTIL SLC SLIDES INTO LOCK POSITION.

**STEP 3:** BUILD (1) ONE CONNECTOR POSITION ASSURANCE (CPA) TO CONNECTOR ASSEMBLY.

- A. HOLD CONNECTOR ASSEMBLY PLUGGING SIDE AWAY FROM HAND. HOLD CPA WITH EXTENSIONS TOWARD CONNECTOR.
- B. SLIDE EXTENSIONS INTO SLOTS AND SNAP INTO PLACE USING FINGERS.

### ASSEMBLY INSTRUCTIONS FEMALE GT 150 CONNECTOR ASSEMBLY

**STEP 1:** PLUG LEADS TO CONNECTOR ASSEMBLY PER PRINT.

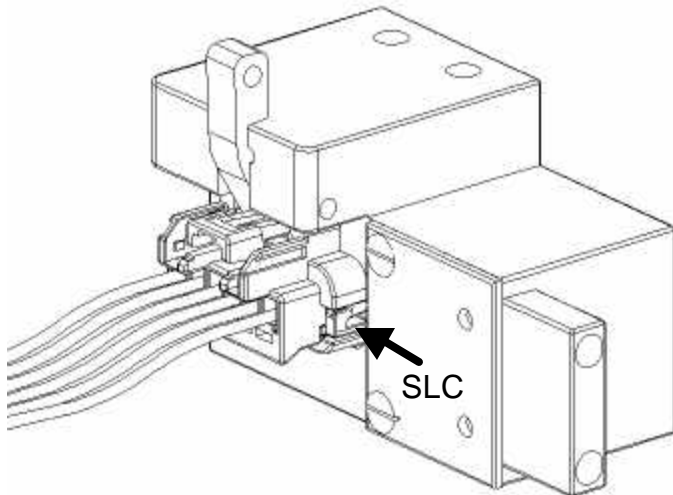
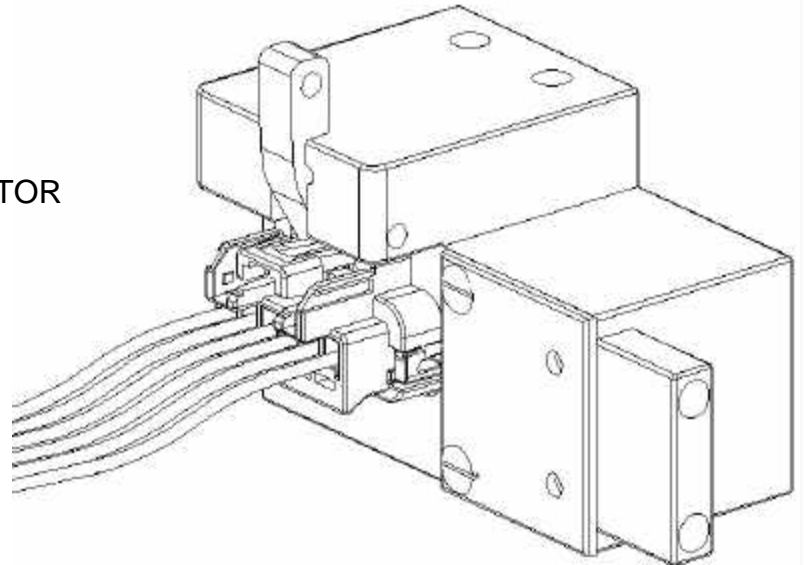

**STEP 2:** AFTER ALL LEADS ARE BUILT, SEAT SIDE LOCK COVER (SLC). CUSTOMERS SHOULD CONTACT DELPHI'S ASSEMBLY TOOLING BUSINESS UNIT FOR THE SPECIFIC COMPONENT ASSEMBLY FIXTURE. THIS FIXTURE SEATS THE SLC TO ITS FINAL STAGE.

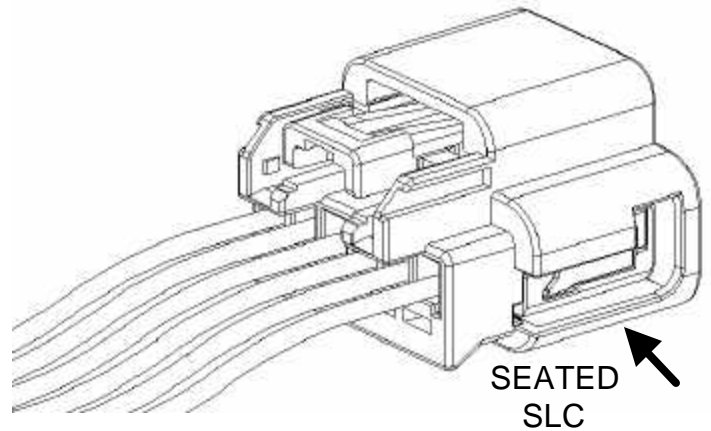

**COMPLETED  
STEP 2**

### ASSEMBLY INSTRUCTIONS FEMALE GT 150 CONNECTOR ASSEMBLY

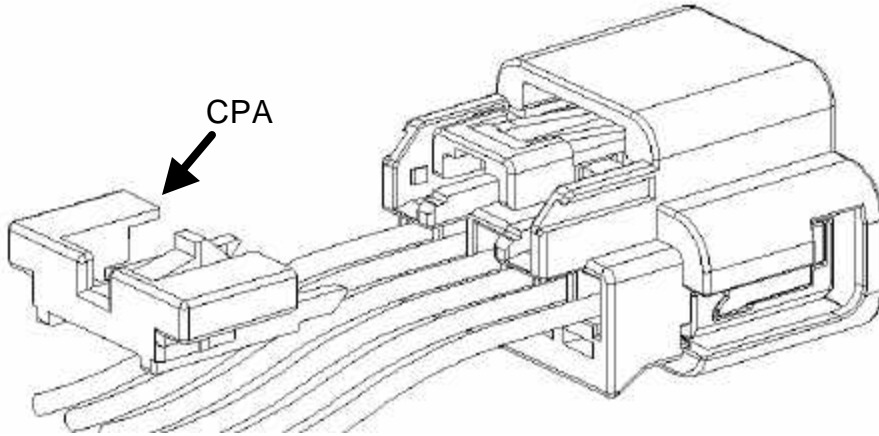

**STEP 3:** BUILD (1) ONE CONNECTOR POSITION ASSURANCE (CPA) TO CONNECTOR ASSEMBLY.

- A. HOLD CONNECTOR ASSEMBLY PLUGGING SIDE AWAY FROM HAND. HOLD CPA WITH EXTENSIONS TOWARD CONNECTOR.
- B. SLIDE EXTENSIONS INTO SLOTS AND SNAP INTO PLACE USING FINGERS.

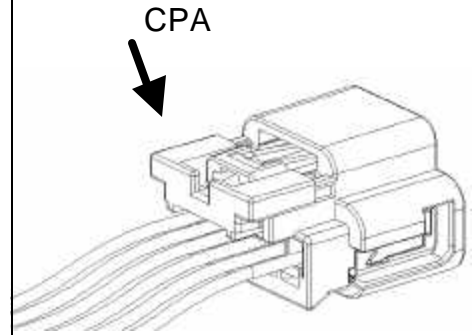

**COMPLETED  
STEP 3**

### ASSEMBLY INSTRUCTIONS MALE GT 150 CONNECTOR ASSEMBLY

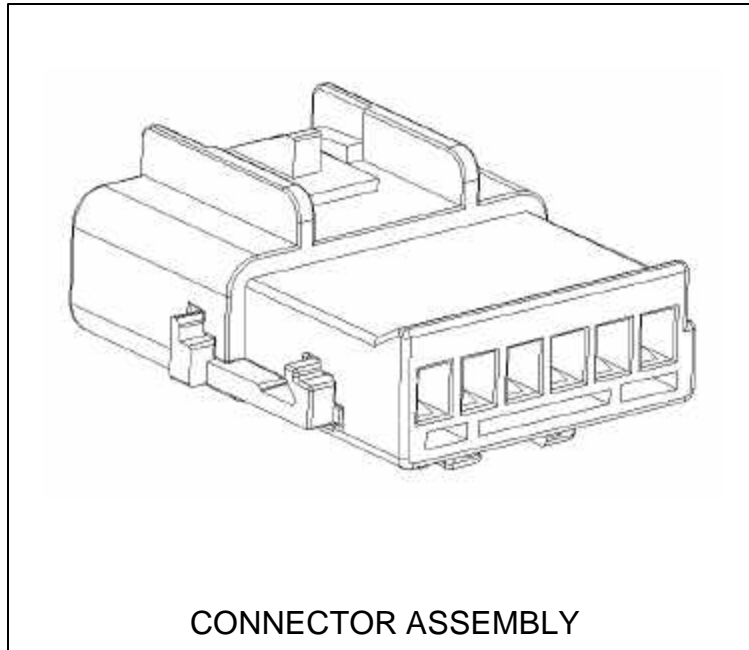

### ASSEMBLY INSTRUCTIONS MALE GT 150 CONNECTOR ASSEMBLY

**STEP 1:** PLUG LEADS TO CONNECTOR ASSEMBLY PER PRINT.

**STEP 2:** AFTER ALL LEADS ARE BUILT, SEAT SIDE LOCK COVER (SLC). APPLY PRESSURE WITH FINGERS UNTIL SLC SLIDES INTO LOCK POSITION.

### ASSEMBLY INSTRUCTIONS MALE GT 150 CONNECTOR ASSEMBLY

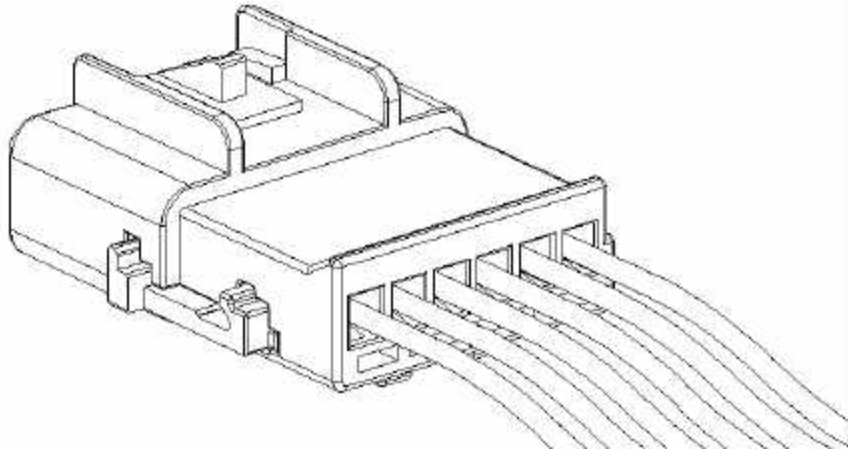

**STEP 1:** PLUG LEADS TO CONNECTOR ASSEMBLY PER PRINT.

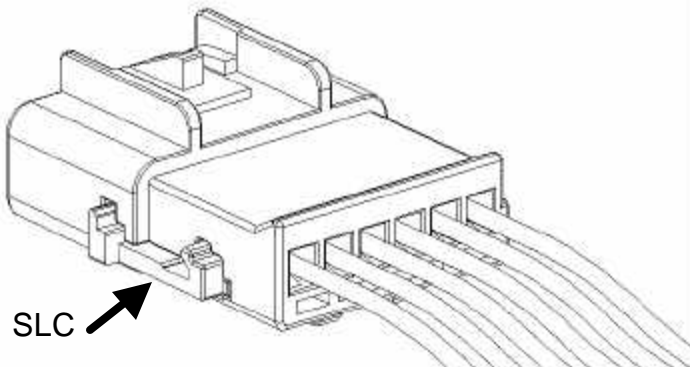

**STEP 2:** AFTER ALL LEADS ARE BUILT, SEAT SIDE LOCK COVER (SLC). APPLY PRESSURE WITH FINGERS UNTIL SLC SLIDES INTO LOCK POSITION.

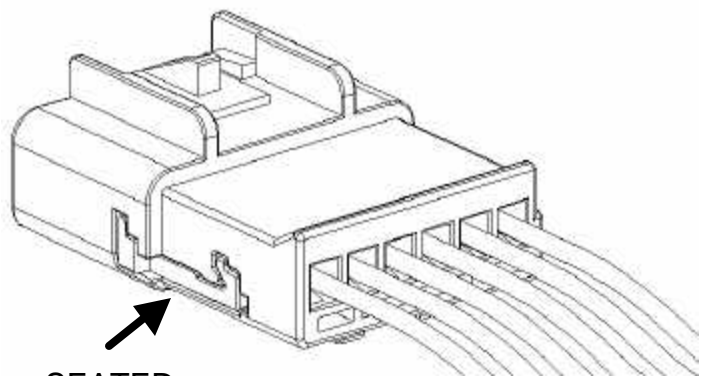

**COMPLETED  
STEP 2**



### FINAL ASSEMBLY INSTRUCTIONS FOR FEMALE & MALE GT 150 CONNECTOR ASSEMBLY

